

Emco-Simplatroll

Industrial Electromagnetic Brakes & Clutches

Type 14.112.XX

Type 14.102.XX

(Normally Off Type)



Flange Mounted Clutch

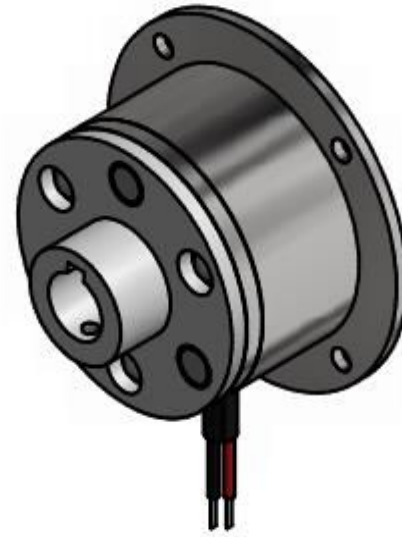

Flange Mounted Brake

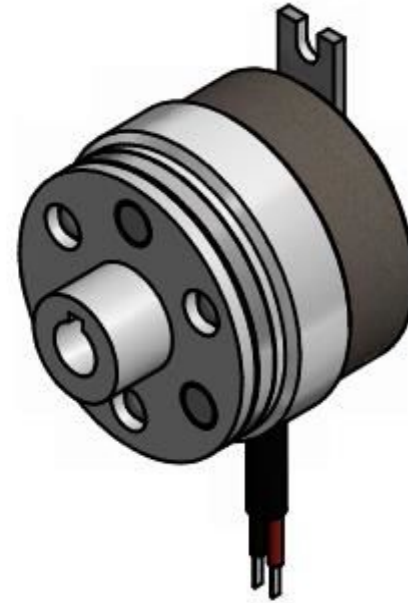

Shaft Mounted Clutch

Salient Features :

- Single Plate Dry Type.
- Zero Backlash.
- Residual-free.
- Fast Switching Times.
- High Operating Reliability.
- High Operating Frequency.
- Compact Dimensions.
- Simple Construction.
- Maintenance-Free.
- Patented Pre-Stressed Spring.
- Stationary Field (No Slip Rings).
- Consistent Operating Characteristics.
- Simple Wear Compensation Adjustment.
- Coil with class "F" Insulation.
- Special Friction Material.
- Simple Installation.
- Low Inertia of Rotating Parts.
- Raw Material to DIN Standards.
- No Restriction on Mounting Position.
- Registered Designs.

Product Information:

Emco electromagnetic clutches and brakes transmit the drive torque or braking torque by friction in dry running conditions. When the DC voltage is applied, torque transmission is achieved free from torsional backlash. The prestressed wave shaped spring on the armature assembly ensures release without residual torque on de-energisation. The clutches and brakes can be used in any mounting position and are virtually maintenance free. Depending on the friction energy used. The working air gap only needs to be checked (and corrected if necessary) at specific time intervals. Special machining of the friction surfaces ensures that the rated torques can be achieved after very few switching operations without a run in period.

The various types of stator and armature assembly enable optimum adaptation to the prevailing operating conditions. The catalogue will help you to select and order the electromagnetic clutch you need.

Catalogue contains:

Electromagnetic clutches : 14.102
Electromagnetic Brakes : 14.112

Emco Dynatorq Pvt. Ltd.

(Formerly Emco Lenze Pvt.Ltd.)

Regd. Office :

1st Floor, Sita Mauli, above Bank of Maharashtra,
Madanlal Dhingra Rode Panch Pakhadi,
Thane (West), 400 602, INDIA
Tel.: +91(0) 22 2540 5490 / 2545 2244 / 2541 5913 / 2541 5914
Fax: +91(0) 22 2545 2233
Email: mktg@emco-dynatorq.in

Website : www.emco-dynatorq.in

Electromagnetic Clutch

14.102 (Flange mounted clutch)

Type:14.102.□□.1.5

Type:14.102.□□.1.3

Type:14.102.□□.1.1

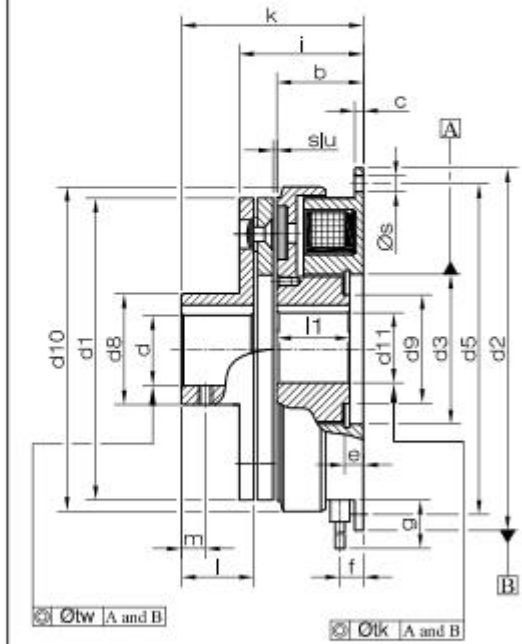
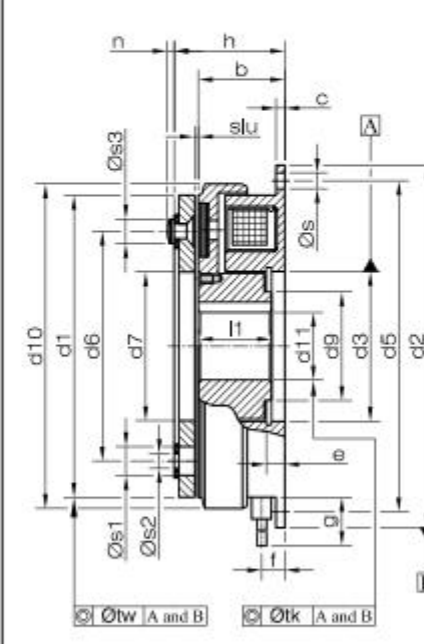
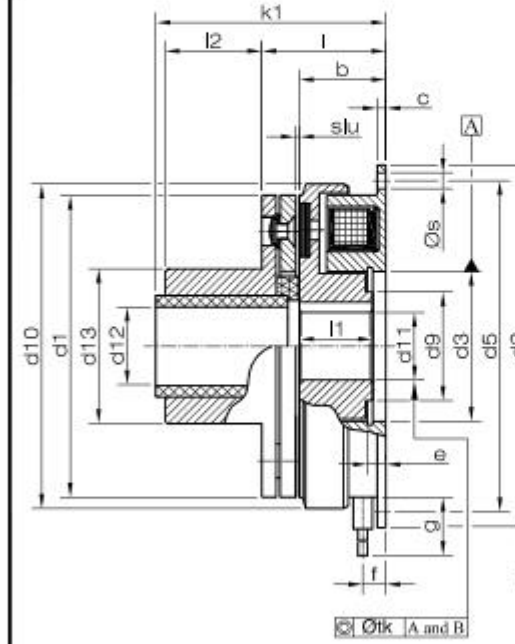

Size	Mk Nm.	P ₂₀ W	b	c	dH7			d ₁	d ₂ h9	d ₃ H8	d ₅	d ₆	d ₇	d ₈	d ₉	d ₁₀	d ₁₁ H7			d ₁₂ H7			d ₁₃ H7		
					min.	Stand.	max.										min.	Stand.	max.	min.	Stand.	max.			
03	0.6	6	22.2	2	6	6	6	32	45	13	38	23	12.5	12	10	34	6	6	6	6	6	6	6	14	
04	1.2	8	25.4	2	8	8	10	40	54	19	47	30	18.5	17	15.5	43	8	8	10	10	8	8	10	10	18
05	2.4	10	28.1	2	10	10	15	50	65	26	58	38	25.5	24	22	54	10	10	15	15	10	10	15	15	28

Size	g	h	i	k	k ₁	l	l ₁	m	n	s	s ₁	s ₂	s ₃	slu	tk	tw
03	400	24.75	26.8	34.8	34.5	10	20.2	4	1.2	4x3.4	3x6	3x2.6	3x4.5	0.15	0.12	0.06
04	400	28.55	31.2	40.6	40.2	12	23.4	5	1.4	4x3.4	3x6	3x3.1	3x5	0.15	0.12	0.06
05	400	31.3	34.3	43.3	43.3	12	26.1	5	1.4	4x3.4	3x6.5	3x3.1	3x6	0.2	0.12	0.06

All dimension are in mm.except where otherwise stated.
Keyways to DIN 6885/ IS:2048.

Electromagnetic Clutch
14.102 (Shaft mounted clutch)

Type:14.102.□□.3.5

Type:14.102.□□.3.3

Type:14.102.□□.3.1

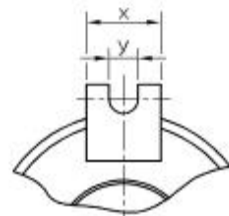
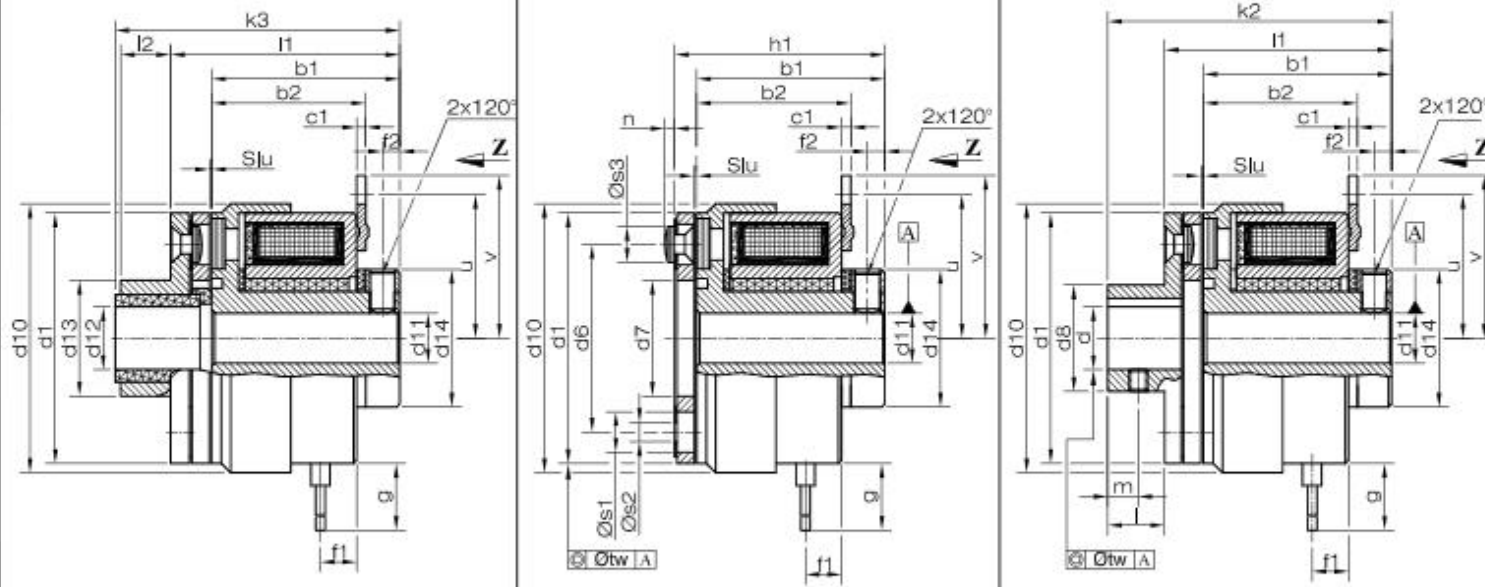

View - Z

Size	Mk Nm.	P ₂₀ W	b ₁	b ₂	c ₁	dH7			d ₁	d ₈	d ₇	d ₈	d ₁₀	d ₁₁ H7			d ₁₂ H7			d ₁₃	d ₁₄	f ₁	f ₂	g		
						min.	Stand.	max.						min.	Stand.	max.	min.	Stand.	max.							
03	0.6	6	26.2	21.9	1.5	6	6	6	32	23	12.5	12	34	6	6	6	6	6	6	14	16	4.7	2.3	400		
04	1.2	8	30.4	25.1	1.5	8	8	10	40	30	18.5	17	43	8	8	10	10	8	8	10	10	18	22	5.2	2.8	400
05	2.4	10	34.1	27.8	1.5	10	10	15	50	38	25.5	24	54	10	10	15	15	10	10	15	15	28	30	6.2	3.3	400

Size	h ¹	i ₁	k ₂	k ₃	l	l ₂	m	n	s ₁	s ₂	s ₃	slu	tw	u	v	x	y
03	28.75	30.8	38.8	38.5	10	7.5	4	1.2	3x6	3x2.6	3x4.5	0.15	0.06	20	23	8	3.1
04	33.55	36.2	45.6	45.2	12	8.7	5	1.4	3x6	3x3.1	3x5	0.15	0.06	23	26	8	3.1
05	37.3	40.3	49.3	49.3	12	8.8	5	1.4	3x6.5	3x3.1	3x6	0.2	0.06	28	31	8	3.1

All dimension are in mm,except where otherwise stated.
 Keyways to DIN 6885/ IS:2048.

Electromagnetic Brake
14.112 (Flange mounted brake)

Type:14.112.□□.1.3

Type:14.112.□□.1.2

Type:14.112.□□.1.1

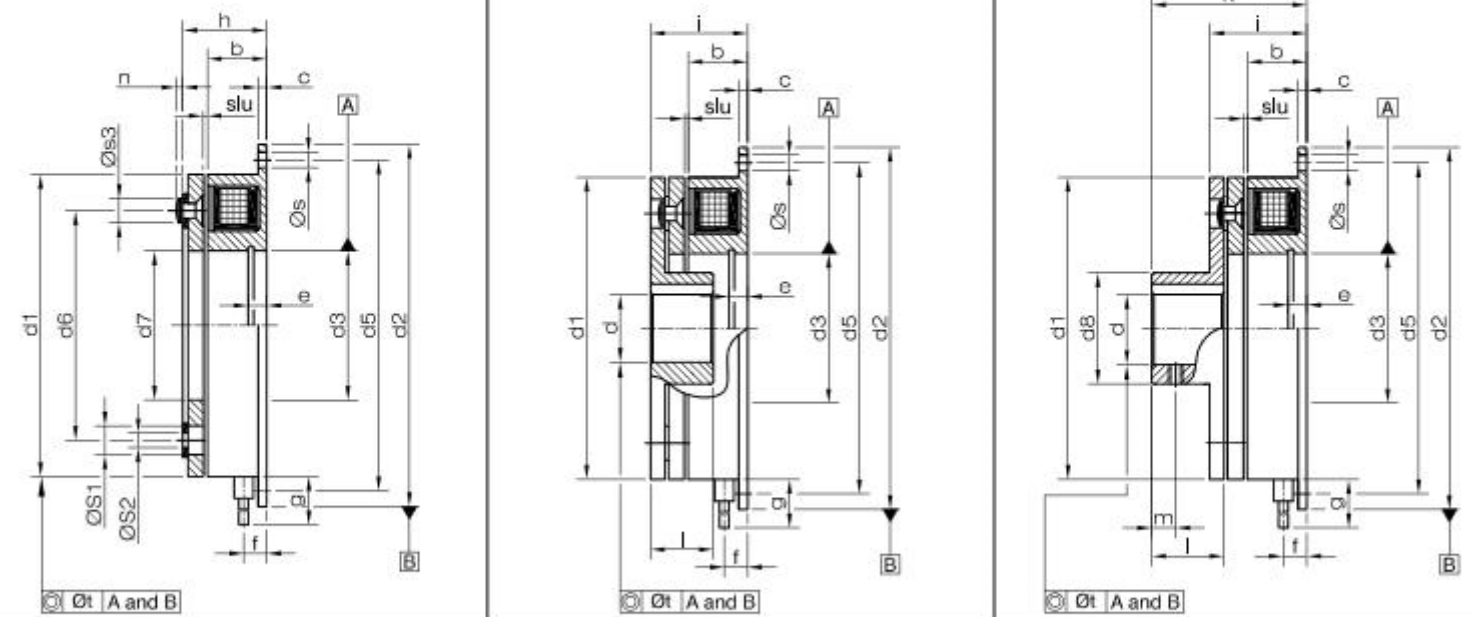

Size	Mk Nm.	P ₂₀ W	b	c	dH7			d ₁ h8	d ₂ h9	d ₃ H8	d ₅	d ₆	d ₇	d ₈	e	f	g	h	i
					min.	Stand.	max.												
03	0.6	6	17	2	6	6	6	32	45	13	38	23	12.5	12	3.1	7.5	400	19.55	21.6
04	1.2	8	20	2	8	8	10	40	54	19	47	30	18.5	17	3.3	8	400	23.15	25.9
05	2.4	10	22	2	10	10	15	50	65	26	58	38	25.5	24	3.3	8	400	25.2	28.2

Size	k	l	m	n	s	s ₁	s ₂	s ₃	slu	t
03	29.6	10	4	1.2	4x3.4	3x6	3x2.6	3x4.5	0.15	0.06
04	35.2	12	5	1.4	4x3.4	3x6	3x3.1	3x5	0.15	0.1
05	37.2	12	6	1.4	4x3.4	3x6.5	3x3.1	3x6	0.2	0.1

All dimension are in mm,except where otherwise stated.
 Keyways to DIN 6885/ IS:2048.

Application areas :

Xerox machines, Envelop sorting machine, Medical Equipment , small motors, wood working machines, automation systems and general mechanical engineering.